

Technical brochure

Solenoid valves, 2/2-way servo-operated type EV220B 6-22



EV220B 6-22 is a direct servo-operated 2/2-way solenoid valve program with connections from 1/4" to 1".

This program is especially for OEM applications demanding a robust solution and moderate flow rates.

Features and versions:

- For water, oil, compressed air and similar neutral media
- Flow range from 0.2 – 19 m³/h
- Differential pressure from 1 – 30 bar
- Media temperature from -30 – 100 °C
- Ambient temperature: Up to 80 °C
- Coil enclosure: Up to IP67
- Thread connections: From G 1/4 – G 1
- DN 6 – 22
- Viscosity: Up to 50 cSt
- Also available with NPT thread.
- Brass version NC and NO
- DZR brass version NC

Solenoid valves, type EV220B 6-22

Brass valve body, NC



Connection ISO 228/1	Seal material	Orifice size	k _v - value [m ³ /h]	Differential pressure min. to max. [bar] / coil type					Media temperature min. to max. [°C]	Code number
				BA	BB/BE	BB/BE	BG	BG		
				9 W a.c.	10 W a.c.	18 W d.c.	12 W a.c.	20 W d.c.		
G 1/4	EPDM ¹⁾	6	0.7	0.1 – 20	0.1 – 20	0.1 – 10	0.1 – 20	0.1 – 20	-30 – 100	032U1236
	FKM ²⁾			0.1 – 20	0.1 – 20	0.1 – 10	0.1 – 20	0.1 – 20	0 – 100	032U1237
G 3/8	EPDM ¹⁾	6	0.7	0.1 – 20	0.1 – 20	0.1 – 10	0.1 – 20	0.1 – 20	-30 – 100	032U1241
	FKM ²⁾			0.1 – 20	0.1 – 20	0.1 – 10	0.1 – 20	0.1 – 20	0 – 100	032U1242
	EPDM ¹⁾	10	1.5	0.1 – 20	0.1 – 20	0.1 – 10	0.1 – 20	0.1 – 20	-30 – 100	032U1246
	FKM ²⁾			0.1 – 20	0.1 – 20	0.1 – 10	0.1 – 20	0.1 – 20	0 – 100	032U1247
G 1/2	EPDM ¹⁾	11.5	2.3	0.1 – 10	0.1 – 10	0.1 – 10	0.1 – 10	0.1 – 10	-30 – 100	032U1279
	FKM ²⁾			0.1 – 10	0.1 – 10	0.1 – 10	0.1 – 10	0.1 – 10	0 – 100	032U1252
	EPDM ¹⁾	12	2.5	0.3 – 10	0.3 – 10	–	–	0.3 – 10	-30 – 100	032U1256
	FKM ²⁾			0.3 – 10	0.3 – 10	–	–	0.3 – 10	0 – 100	032U1255
G 3/4	EPDM ¹⁾	18	6.0	0.3 – 10	0.3 – 10	–	0.3 – 10	0.3 – 10	-30 – 100	032U1261
	FKM ²⁾			0.3 – 10	0.3 – 10	–	0.3 – 10	0.3 – 10	0 – 100	032U1260
G 1	EPDM ¹⁾	22	6.0	0.3 – 10	0.3 – 10	–	0.3 – 10	0.3 – 10	-30 – 100	032U1263
	FKM ²⁾			0.3 – 10	0.3 – 10	–	0.3 – 10	0.3 – 10	0 – 100	032U1266

Brass valve body, NO



Connection ISO 228/1	Seal mate- rial	Ori- fice size	k _v - value [m ³ /h]	Differential pressure min. to max. [bar] / coil type					Media temperature min. to max. [°C]	Code number
				BA	BB/BE	BB/BE	BG	BG		
				9 W a.c.	10 W a.c.	18 W d.c.	12 W a.c.	20 W d.c.		
G 3/8	EPDM ¹⁾	6	0.7	0.1 – 10					-30 – 100	032U1238
	FKM ²⁾	6	0.7						0 – 100	032U1239
G 1/2	FKM ²⁾	10	1.0	0.1 – 10					0 – 100	032U1249

¹⁾ EPDM is suitable for water.

²⁾ FKM is suitable for oil and air. For water at max. 60 °C.

Solenoid valves, type EV220B 6-22

Technical data, NC and NO

Type	EV220B 6B	EV220B 10B	EV220B 12B	EV220B 18B	EV220B 22B
Time to open [ms] ¹⁾	40	50	60	200	200
Time to close [ms] ¹⁾	250	300	300	500	500

¹⁾ The times are indicative and apply to water. The exact times will depend on the pressure conditions.

Installation	Vertical solenoid system is recommended.		
Pressure range	NC: 0.1 – 30 bar NO: 0.1 – 10 bar		
Max.test pressure	EV220B 6 – 10: 50 bar	EV220B 12 – 22: 16 bar	
Ambient temperature	Up to 80 °C. (Depending on coil type, see data for the coil selected)		
Viscosity	Max. 50 cSt		
Materials	Valve body	Brass	W.no. 2.0402
	Armature:	Stainless steel	W.no. 1.4105/AISI 430FR
	Armature tube:	Stainless steel	W.no. 1.4306/AISI 304L
	Armature stop:	Stainless steel	W.no. 1.4105/AISI 430FR
	Springs:	Stainless steel	W.no. 1.4310/AISI 301
	O-rings:	EPDM or FKM	
	Valve plate:	EPDM or FKM	
	Diaphragm:	EPDM or FKM	

Solenoid valves, type EV220B 6-22

Dezincification resistant brass (DZR) brass valve body NC



Con- nection ISO 228/1	Seal mate- rial	Ori- fice size	k _v - value [m ³ /h]	Differential pressure min. to max. [bar] /coil type					Media temperature min. to max. [°C]	Code number
				BA	BB		BE			
				9 W a.c.	10 W a.c.	18 W d.c.	10 W a.c.	18 W d.c.		
G 1/4	EPDM ¹⁾	6	0.7	0.1 – 20	0.1 – 20	0.1 – 10	0.1 – 20	0.1 – 20	-30 – 100	032U5806
G 3/8		6	1.5	0.1 – 20	0.1 – 20	0.1 – 10	0.1 – 20	0.1 – 20		032U5807
		10	1.5	0.1 – 20	0.1 – 20	0.1 – 10	0.1 – 20	0.1 – 20		032U5809
G 1/2		10	2.5	0.1 – 20	0.1 – 20	0.1 – 10	0.1 – 20	0.1 – 20		032U5810
		12	2.5	0.3 – 10	0.3 – 10	–	–	0.3 – 10		032U5811

¹⁾ EPDM is suitable for water .

Technical data NC, Dezincification resistant brass (DZR)

Main type	EV220B 6BD	EV220B 10BD	EV22B 12BD
Time to open [ms] ¹⁾	40	50	60
Time to close [ms] ¹⁾	250	300	300

¹⁾The times are indicative and apply to water. The exact times will depend on the pressure conditions.

Installation	Vertical solenoid system is recommended		
Max. test pressure	50 bar	50 bar	16 bar
Ambient temperature	Up to 80°C. (Depending on coil type, see data for coil selected)		
Viscosity	Max. 50 cSt		
Materials	Valve body	Dezincification resistant brass (DZR)	CuZn36 Pb2As/CZ132
	Armature	Stainless Steel	W.no. 1.4105/AISI 430FR
	Armature tube	Stainless Steel	W.no. 1.4306/AISI 304L
	Armature stop	Stainless Steel	W.no. 1.4105/AISI 430FR
	Springs	Stainless Steel	W.no. 1.4310/AISI 301
	Valve seat	Stainless Steel	W.no. 1.4404/AISI 316L
	O-rings	EPDM	
	Valve plate	EPDM	
Diaphragm	EPDM		

Solenoid valves, type EV220B 6-22

Dimensions and weight: Brass, DZR brass, NC and NO

Type	Weight gross valve body without coil [kg]	L [mm]	B [mm]	B ₁ [mm]			H [mm]	H ₁ [mm]
				Coil type BA	Coil type BB/BE	Coil type BG		
EV220B 6B	0.22	45.5	43.5	32	46	68	74.0	13.0
EV220B 10B / 11.5B	0.29	51.5	48.0	32	46	68	77.0	13.0
EV220B 12B	0.35	58.0	54.0	32	46	68	77.0	13.0
EV220B 18B	0.65	90.0	62.0	32	46	68	83.0	18.0
EV220B 22B	0.65	90.0	62.0	32	46	68	98.0	18.0

Dimensions

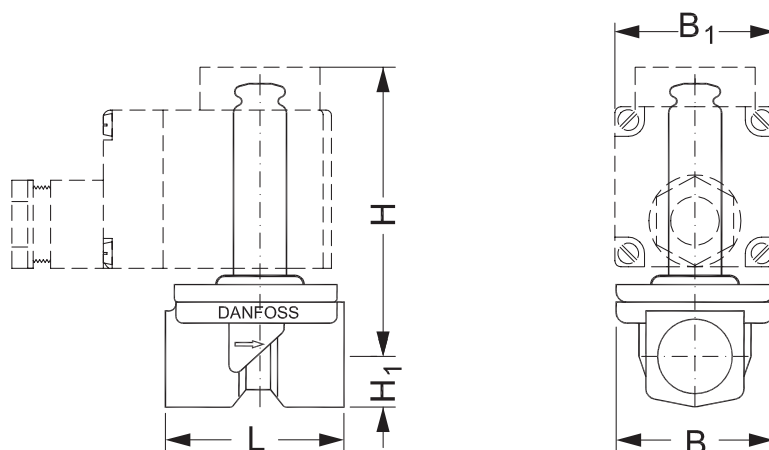

Solenoid valves, type EV220B 6-22
Below coils can be used with EV220B 6-22

Coil	Type	Power consumption	Enclosure	Features
	BA / BD, screw on	9 W a.c. 15 W d.c.	IP00 with spade connector	IP20 with protective cap, IP65 with cable plug
	BB, clip on	10 W a.c. 18 W d.c.	IP00 with spade connector	IP20 with protective cap, IP65 with cable plug
	BE, clip on	10 W a.c. 18 W d.c.	IP67	With terminal box
	BF, clip on	10 W a.c. 18 W d.c.	IP67	With 1 m cable
	BG, clip on	12 W a.c. 20 W d.c.	IP67	With terminal box
	BN, clip on	20 W 26 VA	IP67	Hum free With terminal box and 1 m cable
	BO, screw on	10 W 21 VA	IP67 only including seal kit 018Z0090	For explosion-risk environment zone 1. With terminal box and 5 m cable
	BP, screw on	12 W 10.5 W	IP67 only including seal kit 018Z0090	For explosion-risk environment zone 1. With 3 m cable

For further information and for ordering, see separate data sheet for coils.

Solenoid valves, type EV220B 6-22

Universal electronic multi-timer, type ETM



Application	Voltage	To use with coil:	Ambient temperature [°C]	Code number
External adjustable timing from 1 to 45 minutes with 1 to 15 seconds drain open. With manual override (test button). Electrical connection DIN 43650 A / EN 175 301-803-A	24 – 240 V a.c.	BA, BD, BB	-10 – 50	042N0185

- Outside adjustments
- Light weight and small size
- External adjustable timing from 1 minute to 45 minutes with 1 to 15 seconds drain open
- One solid state timer fits all coil voltages from 24-240 V a.c
- Light diodes for indication
- All in one unit
- Manual override (test button)

Technical data

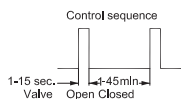

Type	ET 20 M
Voltage	24 – 240 V a.c/ 50 – 60 Hz.
Power rating	Max. 20 Watt
Enclosure	IP 00, IP 65 with cable plug
Electrical connection	DIN connector (DIN 43650-A)
Ambient operating temperature range	-10°C – 50°C
Function	Start with pulse
Interval timer	1 – 45 min.
“On” timer	1 – 15 Sec.
Weight	0.084 kg

Dimensions

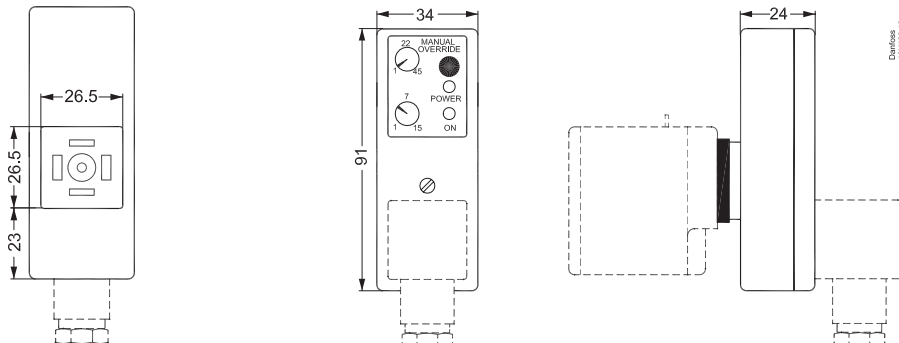

Danfoss
42N02210

Solenoid valves, type EV220B 6-22

Spare parts kit for EV220B 6 - 22 B, NC (brass body) EV220B 6 - 12 BD (dezincification resistant brass body)

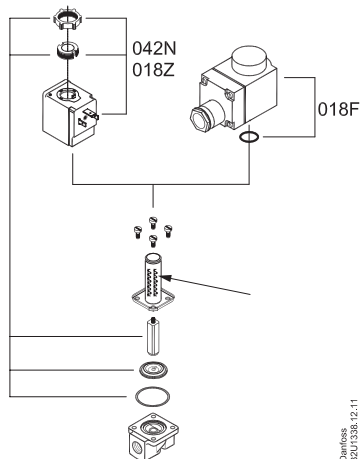

Type	Seal material	Code number
EV220B 6B	EPDM ¹⁾	032U1062
EV220B 6B	FKM ²⁾	032U1063
EV220B 10B	EPDM ¹⁾	032U1065
EV220B 10B	FKM ²⁾	032U1066
EV220B 12B	EPDM ¹⁾	032U1068
EV220B 12B	FKM ²⁾	032U1067
EV220B18-22	EPDM ¹⁾	032U1070
EV220B18-22	FKM ²⁾	032U1069
EV220B 6BD	EPDM ¹⁾	032U4280
EV220B 10BD	EPDM ¹⁾	032U4281
EV220B 12BD	EPDM ¹⁾	032U4283

¹⁾ EPDM is suitable for water.

²⁾ FKM is suitable for oil and air. For water at max. 60 °C.

The EV220B 6 – 10 spare parts kit comprises:

Locking button
Nut for the coil
Armature with valve plate and spring
Diaphragm
O-ring

The EV220B 12 – 22 spare parts kit comprises:

Locking button
Nut for the coil
Armature with valve plate and spring
Diaphragm

EV220B 6-10B



EV220B 12-22B



Assembled NO unit

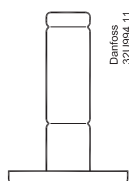

EV220B 6 - 10B; NO		
Type	Seal material	Code number
EV220B 6B	EPDM ¹⁾	032U0165
EV220B 6B	FKM ²⁾	032U0166
EV220B 10B	FKM ²⁾	032U0167

¹⁾ EPDM is suitable for water.

²⁾ FKM is suitable for oil and air. For water at max. 60 °C.

The spare part kit comprises:

NO actuator unit
Locking button
Nut for coil
O-ring



Function, NC

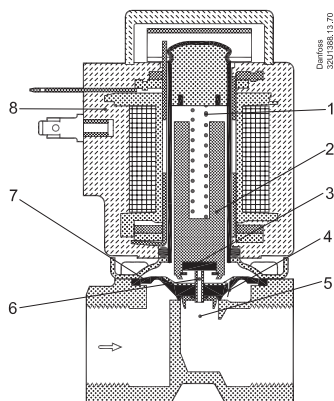

1. Armature spring
2. Armature
3. Valve plate
4. Equalising orifice
5. Main orifice
6. Pilot orifice
7. Diaphragm
8. Coil

Coil voltage disconnected (closed):

When the supply voltage to the coil (8) is disconnected, the valve plate (3) is pressed down against the pilot orifice (6) by the armature spring (1). The pressure across the diaphragm (7) is built up via the equalising orifice (4). The diaphragm closes the main orifice (5) as soon as the pressure across the diaphragm is equivalent to the inlet pressure. The valve will be closed for as long as the voltage to the coil is disconnected.

Coil voltage connected (open):

When voltage is applied to the coil, the pilot orifice (6) is opened. As the pilot orifice is larger than the equalising orifice (4), the pressure across the diaphragm (7) drops and therefore it is lifted clear of the main orifice (5). The valve is now open and will be open for as long as the minimum differential pressure across the valve is maintained, and for as long as there is voltage to the coil.

Function, NO

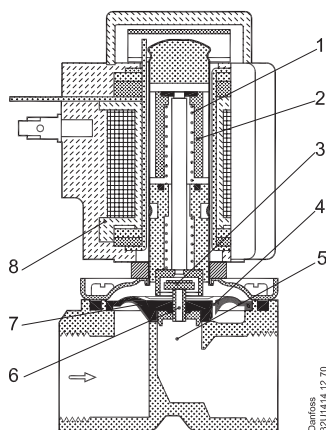

1. Opening spring
2. Armature
3. Valve plate
4. Equalising orifice
5. Main orifice
6. Pilot orifice
7. Diaphragm
8. Coil

Coil voltage disconnected (open):

When the voltage to the coil (8) is disconnected, the pilot orifice (6) is open. As the pilot orifice is larger than the equalising orifice (4), the pressure across the diaphragm (7) drops and therefore it is lifted clear of the main orifice (5). The valve will be open for as long as the minimum differential pressure across the valve is maintained, and for as long as the voltage to the coil is disconnected.

Coil voltage connected (closed):

When voltage is applied to the coil, the valve plate (3) is pressed down against the pilot orifice (6). The pressure across the diaphragm (7) is built up via the equalising orifice (4). The diaphragm closes the main orifice (5) as soon as the pressure across the diaphragm is equivalent to the inlet pressure. The valve will be closed for as long as there is voltage to the coil.

Solenoid valves, type EV220B 6-22

Capacity diagram:

Example, water: EV220B 10 NC,
at 4 bar diff. pressure: Approx: 3 m³/h

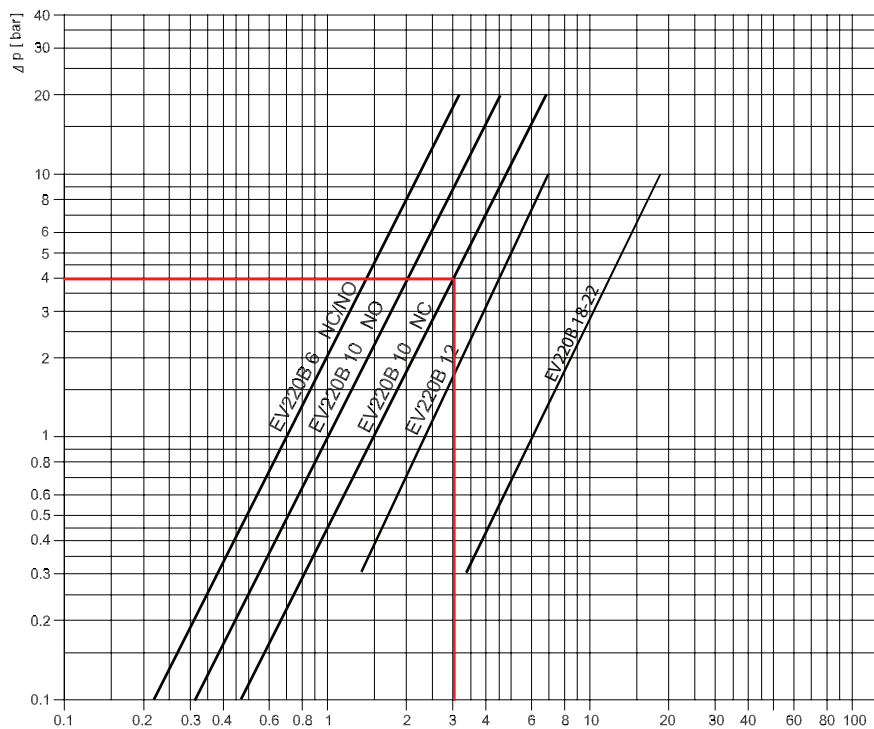

A.P.O. - ELMOS v.o.s., Pražská 90, 509 01 Nová Paka, Tel.: +420 493 504 261, Fax: +420 493 504 257, E-mail: apo@apoelmos.cz, Internet: www.apoelmos.cz

Danfoss can accept no responsibility for possible errors in catalogues, brochures and other printed material. Danfoss reserves the right to alter its products without notice. This also applies to products already on order provided that such alterations can be made without consequential changes being necessary in specifications already agreed. All trademarks in this material are property of the respective companies. Danfoss and the Danfoss logotype are trademarks of Danfoss A/S. All rights reserved.